



DRILL PIPE FLOAT VALVE



Drillmax manufactures a full line of drill pipe float valves also known as “**blue valves**” are engineered for optimum performance and reliability. The blue float valve prevents drilling fluids, cuttings and metal debris from flowing back up the drill string. When correctly installed on the drill string these blue valves provide added blowout prevention.

Drillmax Drill Pipe (DP) Float valves are available for standard service, **H2S – 300°F** service (HNBR/HSN) and **H2S – 400°F** service (Viton.)



www.raahsafety.com



Sales@raahsafety.com

10K Plunger Style

1. Model F Plunger Type (Piston or Dart)

- It allows constant fluid flow while drilling, yet provides an instant shut-off if the flow is stopped or reversed.
- A steady flow of drilling fluid serves to cool & clean the drill bit, removing cuttings from the borehole & preventing clogging, which could otherwise impede progress.

Model F sizes : 2F3R, 3½IF, 4R, 5R, 5F6R

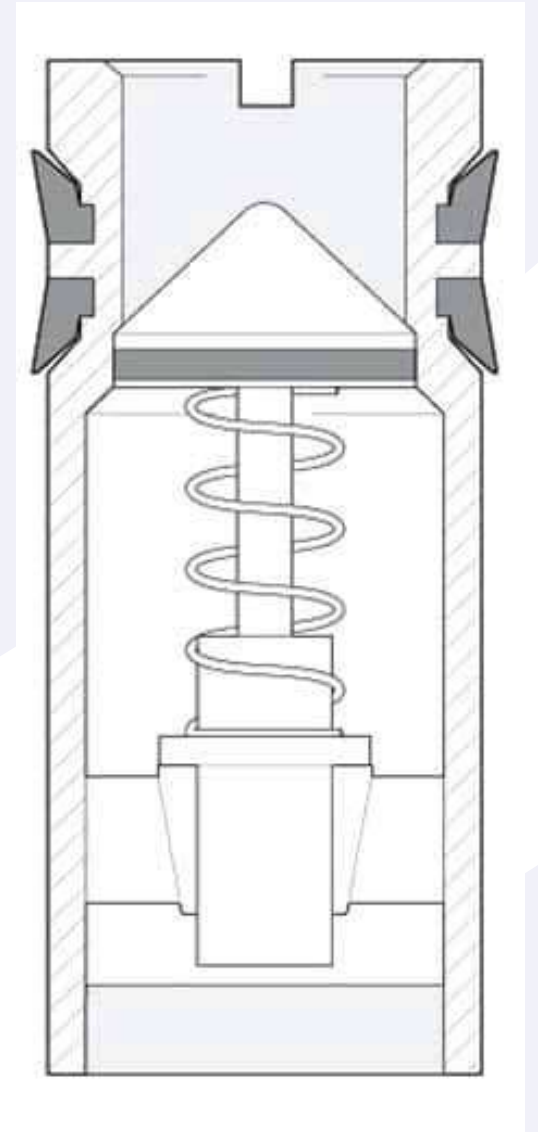

10K Flapper Style

1. Model G Flapper Type Float Valve

Full Flow Flapper Type

- The Model G is a flapper type float valve that offers unobstructed flow through the float valve.
- It's designed for abrasive drilling fluids.
- The Model G features an investment cast flapper that is quick opening, allowing full flow through the valve.

Model G, sizes : 2F3R, 3½IF, 4R, 5R, 5F6R

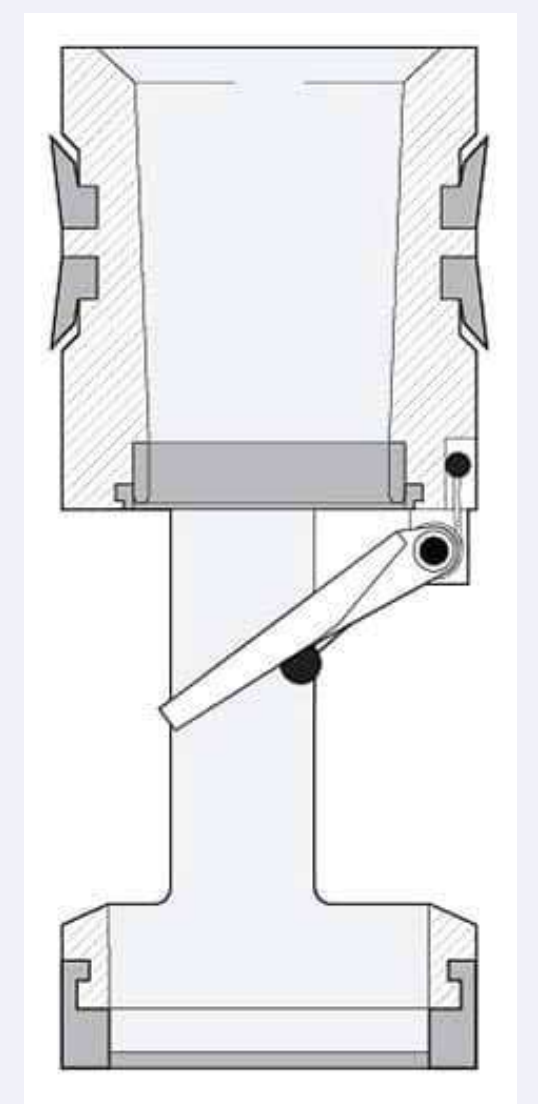

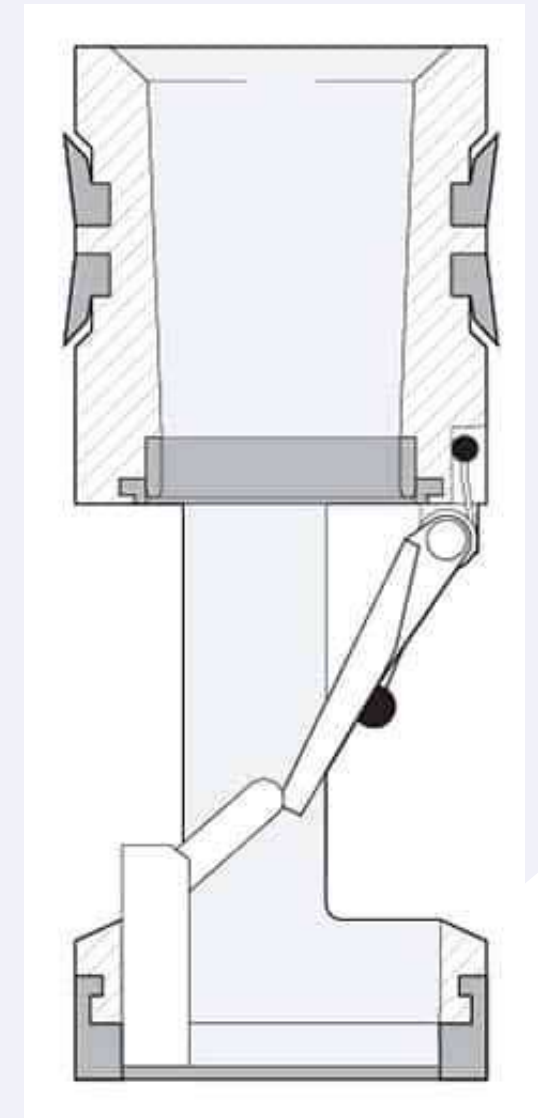

2. Model GC Flapper Type Float Valve

Full Flow Flapper Type Automatic Fill

- The Model GC is identical to the Model G but adds an automatic fill feature when going in the hole
- The valve operates as a Model G as soon as the mud is pumped down the drill string.

Model GC, sizes : 2F3R, 3½IF, 4R, 5R, 5F6R

10K Plunger Style Repair Kits



Model F Metal

- 1 ea Valve Springs
- 1 ea Valve Guide
- 1 ea Plunger Valve
- 1 ea Valve Seal Disc



Model F Rubber

- 2 ea Side Seals
- 1 ea Valve Seals



10K Plunger Style Repair Kits



Model G, and GC Rubber Repair Kit

- 2 ea Side Seals
- 1 ea Valve Seals
- 1 ea Shock Absorber
- 1 ea Seal Retaining Ring



Model G, and GC Metal Repair Kit

- 1 ea Seal Retaining Ring
- 1 ea Hinge Pins
- 1 ea Spring Assemblies
- 1 ea Flapper Valve



7.5K Plunger Style



1. Model F Plunger Type Float Valve (Piston or Dart)

The Model F is a plunger type float valve that allows constant fluid flow while drilling, yet provides an instant shut-off if the flow is stopped or reversed.

Model F sizes: 1R, 4R, 1F2R, 4F, 2F3R, 5R, 3F, 5F6R, 3½ IF, 6F

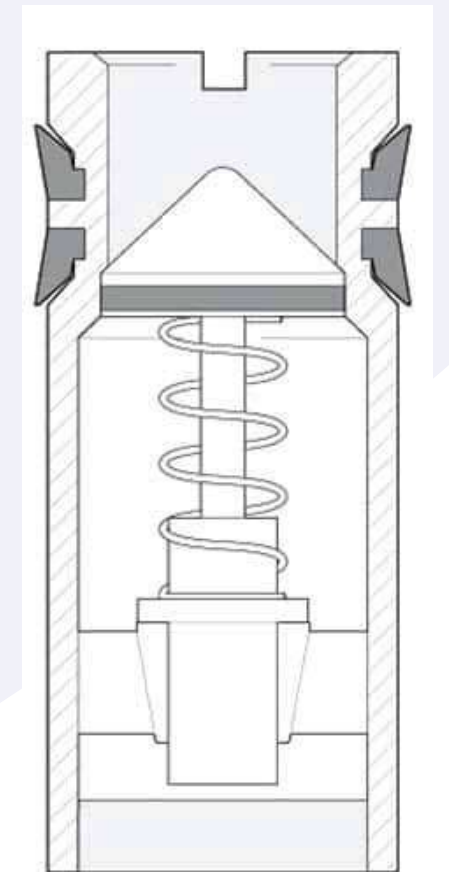

2. Model FA Ported Plunger Type Float Valve

The Model FA offers all the standard features of the Model F with the added benefit of a ported plunger, a special port which allows fluid a path through the center of the valve.

Model FA sizes: 1R, 4R, 1F2R, 4F, 2F3R, 5R, 3F, 5F6R, 3½ IF, 6F

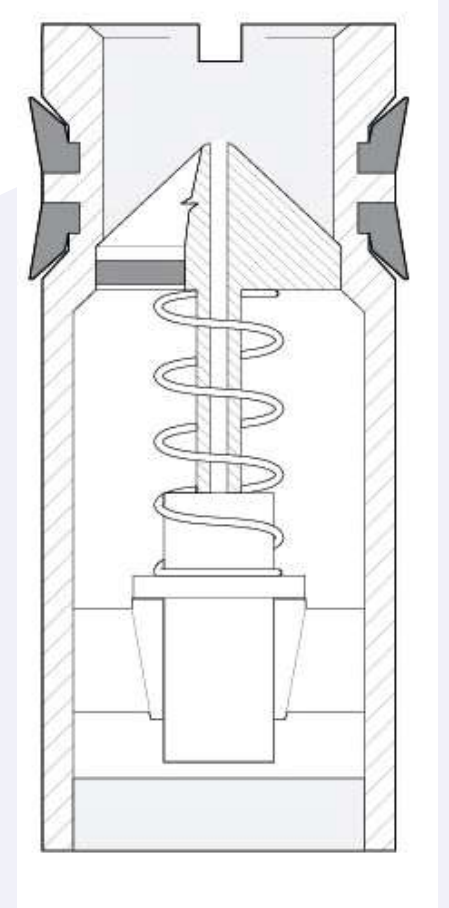

3. Model FBP/FBPA

Helps prevent damage to drilling motors and BHA tools, from recorders, other wireline tools, and debris that are dropped down the string

Model FBP/FBPA sizes: 1R, 4R, 1F2R, 4F, 2F3R, 5R, 3F, 5F6R, 3½ IF, 6F

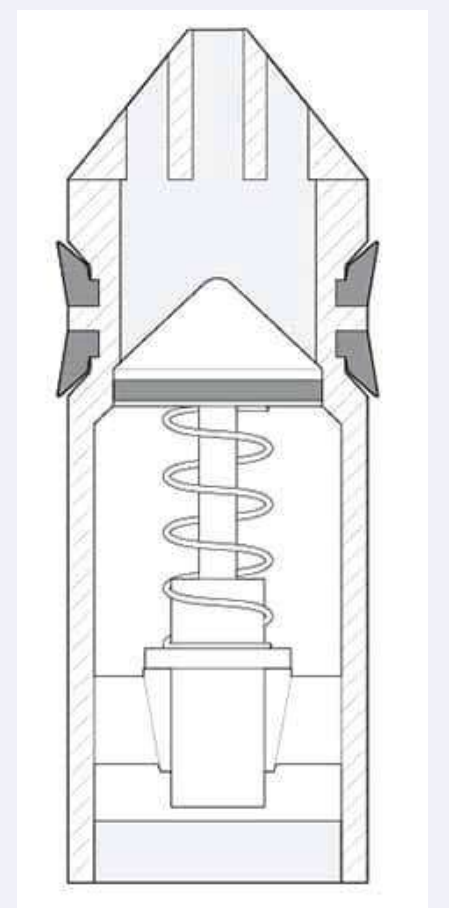

7.5K Flapper Style

1. Model G Flapper Type Float Valve

Full Flow Flapper Type

The Model G is a flapper type float valve that offers unobstructed flow through the float valve.

It's designed for abrasive drilling fluids.

Model G sizes: 1F2R, 4F, 2F3R, 4FGS*, 3F, 5R, 3½ IF, 5F6R, 4R

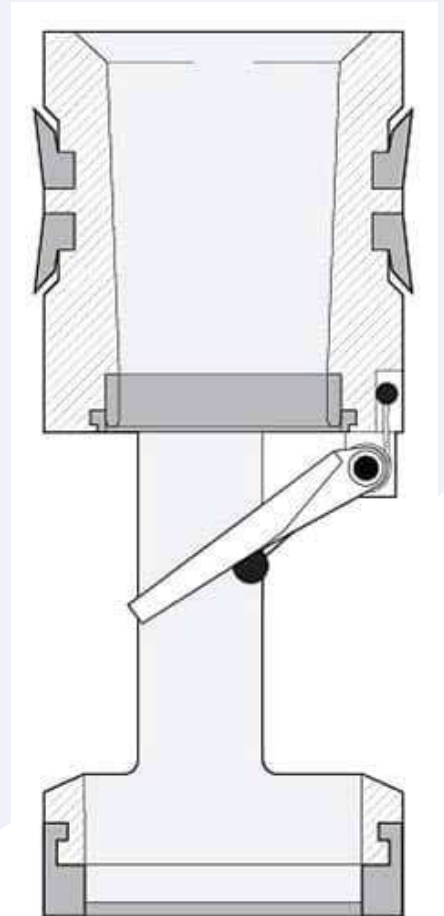

2. Model GA Flapper Type Float Valve

Full Flow Flapper Type with Carbide Insert Port

The Model GA is identical to the Model G except for a small hole in the middle of the flapper, makes the flapper ported.

Model GA sizes: 1F2R, 4F, 2F3R, 4FGS*, 3F, 5R, 3½ IF, 5F6R, 4R

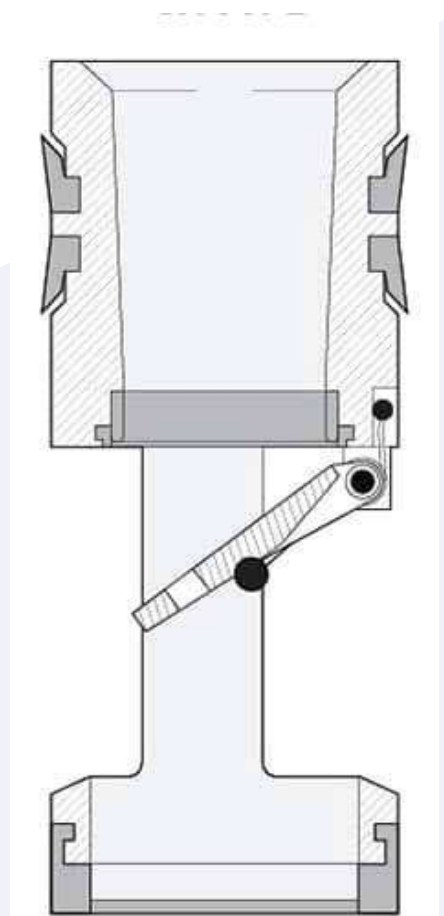

3. Model GC Flapper Type Float Valve

Full Flow Flapper Type Automatic Fill

The Model GC is identical to the Model G but adds an automatic fill feature when going in the hole.

Model GC sizes: 1F2R, 4F, 2F3R, 4FGS*, 3F, 5R, 3½ IF, 5F6R, 4R

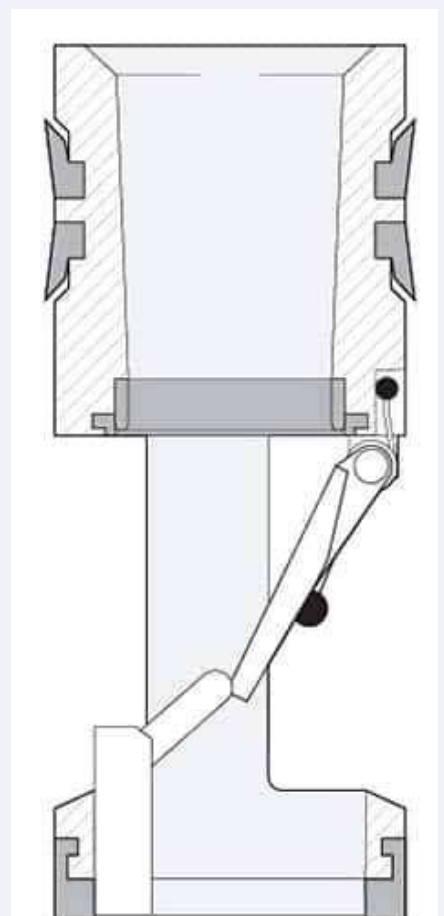



4. Model GCA Flapper Type Float Valve

Full Flow Flapper type for automatic fill with Carbide Insert Port

The Model GCA is identical to the Model GA but adds an automatic fill feature that permits automatic filling of the drill pipe from the bottom and measuring differential pressures from the surface.

Model GCA sizes: 1F2R, 4F, 2F3R, 4FGS, 3F, 5R, 3½ IF, 5F6R, 4R

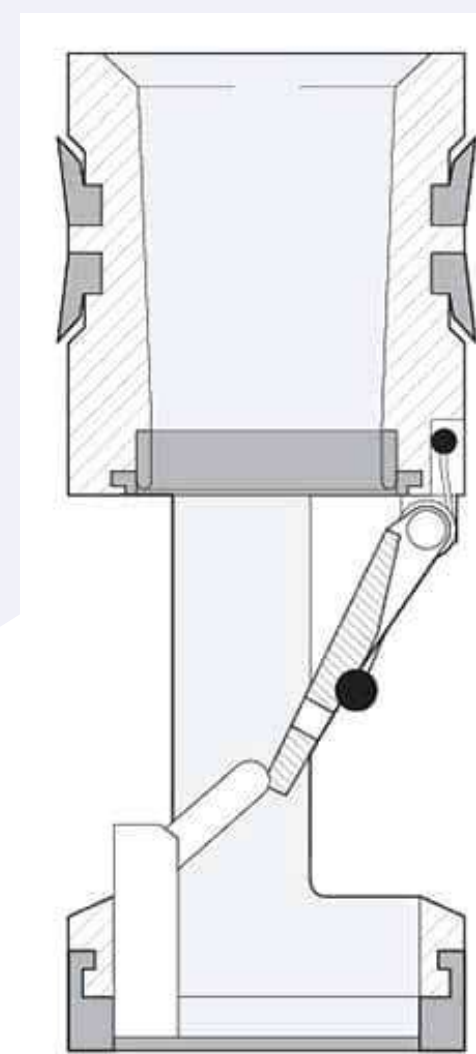

5. Model GS Flapper Type Float Valve

Full Flow Flapper Type

The Model GS is designed and sized for use in drilling motors and performs well in erosive high flow, and corrosive H₂S sour gas conditions.

Model GS sizes: 1F2R, 4F, 2F3R, 4FGS*, 3F, 5R, 3½ IF, 5F6R, 4R

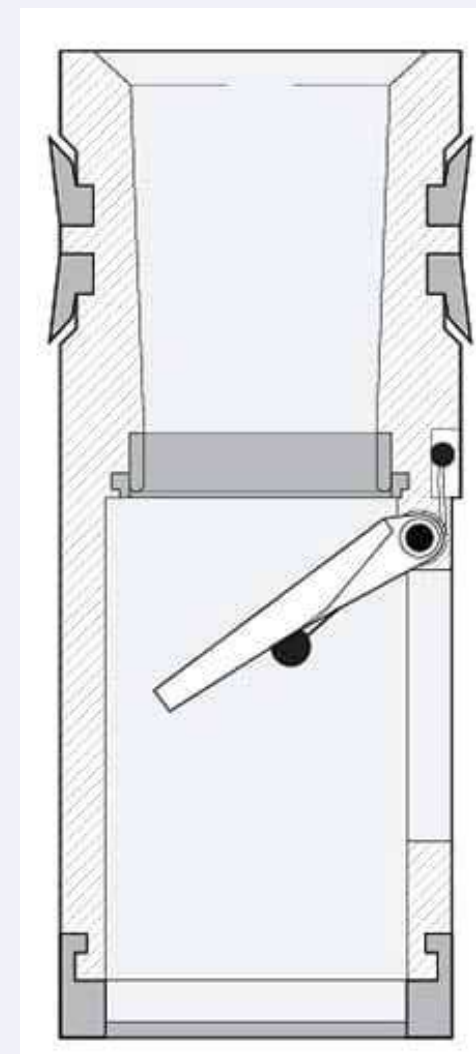



7.5K Repair Kits

7.5K Plunger



Model F, FA, FBP, & FBPA Rubber

- 8 ea Side Seals
- 2 ea Valve Seals



Model F and FBP Metal

- 3 ea Valve Springs
- 1 ea Valve Guide
- 1 ea Plunger Valve
- 1 ea Valve Seal Disc



Model FA & FBPA Ported Plunger Metal

- 3 ea Valve Springs
- 1 ea Valve Guide
- 1 ea Plunger Valve
- 1 ea Valve Seal Disc



7.5K Flapper



Model G, GA, GC, GCA, and GS Rubber Repair Kit

- 8 ea Side Seals
- 2 ea Valve Seals
- 1 ea Shock Absorber
- 1 ea Seal Retaining Ring



Model G, GC, and GS Metal Repair Kit

- 1 ea Seal Retaining Ring
- 3 ea Hinge Pins
- 3 ea Spring Assemblies
- 1 ea Flapper Valve



Model GA and GSA Ported Flapper Metal Repair Kit

- 1 ea Seal Retaining Ring
- 3 ea Hinge Pins
- 3 ea Spring Assemblies
- 1 ea Flapper Valve





Model G and GA 1F2R Rubber Repair Kit

- 8 ea Side Seals
- 2 ea Valve Seals
- 1 ea Shock Absorber



Model G 1F2R Metal Repair Kit

- 3 ea Hinge Pins
- 3 ea Spring Assemblies
- 1 ea Flapper Valve



Model GA 1F2R Ported Flapper Metal Repair Kit

- 3 ea Hinge Pins
- 3 ea Spring Assemblies
- 1 ea Flapper Valve





Baffle Plates

Drillmax baffle plates protect float valves, drilling motors, and other bottom hole assembly (BHA) equipment from damage caused by recorders, wireline instruments, or foreign objects dropped down the drill string. Available in spider or ring type.

- Interchangeable with Totco baffle plates.
- Available for bit, float valve, or drill string tool joint
- For use in API regular, internal flush, full hole, Xtra Hole, NC, XT, WT, and other connections
- Drillmax Model FBP float valves include a permanent, shatter-proof integral baffle plate



www.raahsafety.com



Sales@raahsafety.com